

ASAHI AV

ASAHI AV VALVES AND PIPING SYSTEMS

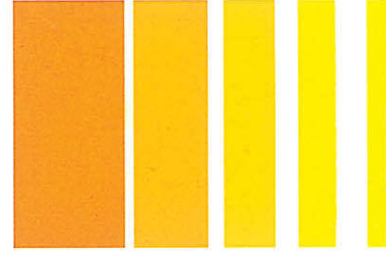

ASAHI ORGANIC CHEMICALS INDUSTRY CO.,LTD.

Asahi AV Products Have Been Certified to Meet the Requirements of ISO 9001.

ISO 9000 Series

The ISO 9000 standards, set by the International Standards Organization (ISO), evaluates and certifies a quality control system.

Certification

Applicable standards: ISO 9001-1994 and JIS Z 9901-1994
 Certified factory: Nobeoka Factory
 Scope of certification: Designs and manufacturing process of synthetic resin valves (Asahi AV valves)
 Assessor: JIA-QA

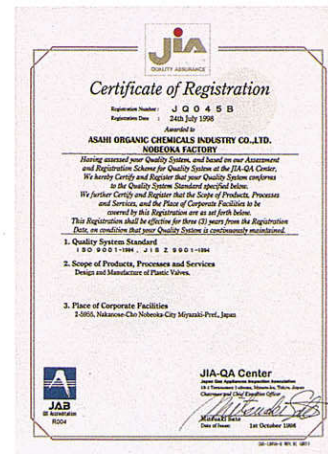

Asahi AV valves are Japan's first plastic valves to be certified to conform to ISO 9001.

Abbreviations for Major Materials Used For Asahi AV Products

Symbol	Description
U-PVC	"PVC" is an abbreviation for "polyvinyl chloride." "U" in "U-PVC" means "unplasticized" "U-PVC" refers to "unplasticized polyvinyl chloride."
C-PVC	The first letter "C" means to "chlorinated." "C-PVC" refers to "chlorinated polyvinyl chloride," or heat-resistant polyvinyl chloride.
HI-PVC	The first lettering "HI" means "high impact." "HI-PVC" refers to "high impact resist polyvinyl chloride."
PP	"PP" is an abbreviation for "polypropylene."
PVDF	"PVDF" is an abbreviation for "polyvinylidene fluoride."
FRP	"FRP" is an abbreviation for "fiber reinforced plastics."
ABS	"ABS" is an abbreviation for "acrylonitrile butadiene styrene."
PPS	"PPS" is an abbreviation for "polyphenylenesulfide."
PEEK	"PEEK" is an abbreviation for "polyether ether ketone."
PTFE	"PTFE" is an abbreviation for "poly tetra fluoro ethylene."
EPDM	"EPDM" is an abbreviation for "ethylene propylene diene rubber."
FPM	"FPM" is an abbreviation for "fluorocarbon rubber."
SBR	"SBR" is an abbreviation for "styrene butadiene rubber."
NBR	"NBR" is an abbreviation for "acrylonitrile butadiene rubber."
IIR	"IIR" is an abbreviation for "isobutylene isoprene rubber."
CSM	"CSM" is an abbreviation for "chlorosulphonated polyethylene."
CR	"CR" is an abbreviation for "chloroprene rubber."

ASAHI AV VALVES AND PIPING SYSTEMS

■ The specifications in this brochure are subject to change without prior notice due to improvements and modifications.

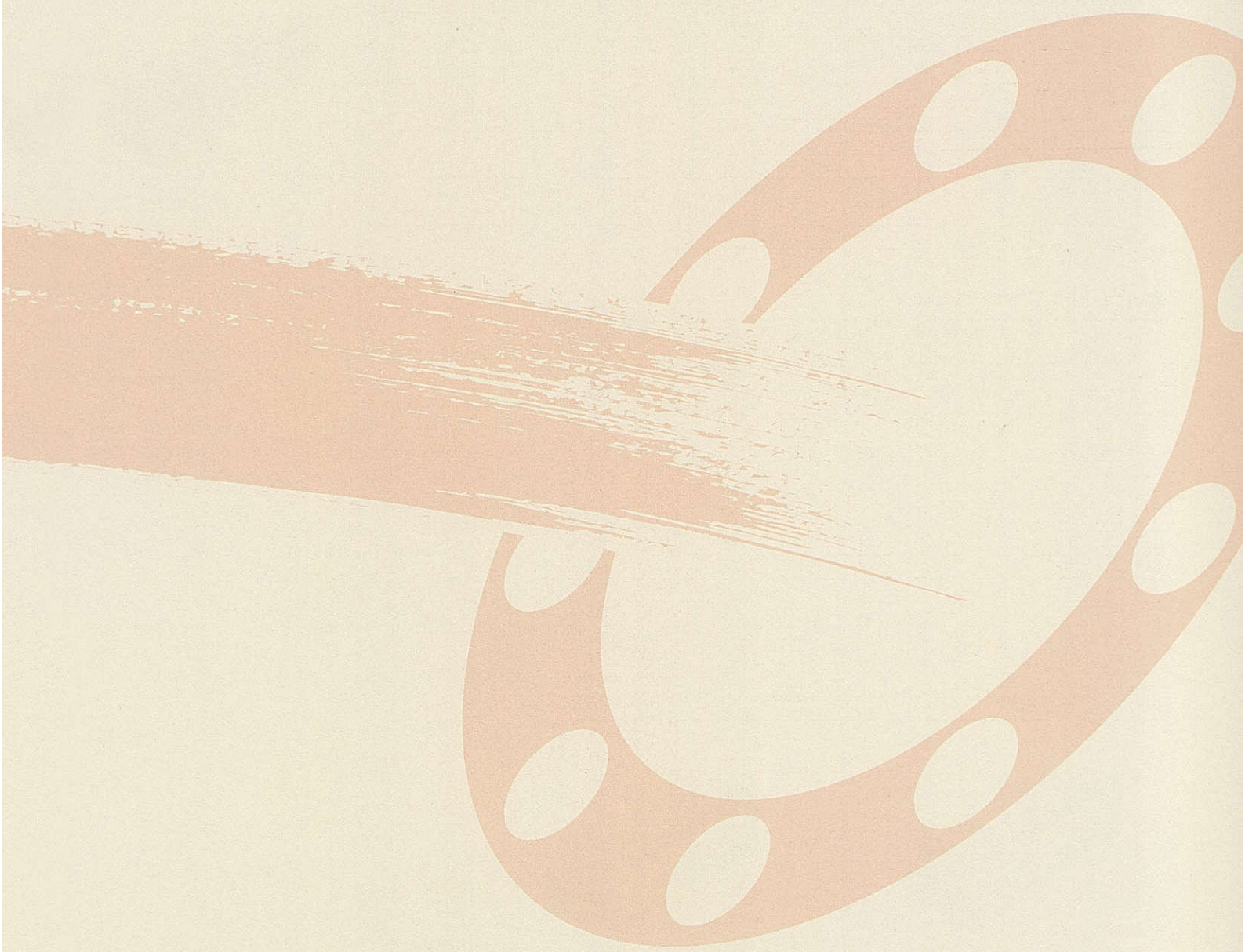

VINYL PIPES

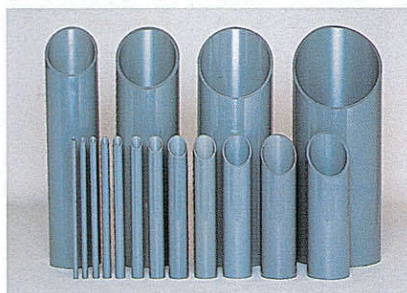

●Unplasticized Polyvinyl Chloride Pipes

ORDINARY PIPE (VP) - JIS K6741 / **K6742**
 THIN-WALLED PIPE (VU) - JIS K6741

●VP Type

Unit:mm

Nom. Size (mm)	Identification	Outer diameter			Thickness		Approximate Inner diameter	Length	Calculated Weight (kg/m)	HI-VP PIPE
		Basic Dimension (mm)	Max. Min. Tolerance	Average Tolerance	Min. Dimension	Tolerance				
13	VP 13	18	±0.2	±0.2	2.2	±0.6	13	4,000	0.174	●
16	VP 16	22	±0.2	±0.2	2.7	±0.6	16	4,000	0.256	●
20	VP 20	26	±0.2	±0.2	2.7	±0.6	20	4,000	0.310	●
25	VP 25	32	±0.2	±0.2	3.1	±0.8	25	4,000	0.448	●
30	VP 30	38	±0.3	±0.2	3.1	±0.8	31	4,000	0.542	●
40	VP 40	48	±0.3	±0.2	3.6	±0.8	40	4,000	0.791	●
50	VP 50	60	±0.4	±0.2	4.1	±0.8	51	4,000	1.122	●
65	VP 65	76	±0.5	±0.3	4.1	±0.8	67	4,000	1.445	●
75	VP 75	89	±0.5	±0.3	5.5	±0.8	77	4,000	2.202	●
100	VP100	114	±0.6	±0.4	6.6	±1.0	100	4,000	3.409	●
125	VP125	140	±0.8	±0.5	7.0	±1.0	125	4,000	4.464	●
150	VP150	165	±1.0	±0.5	8.9	±1.4	146	4,000	6.701	●
200	VP200	216	±1.3	±0.7	10.3	±1.4	194	4,000	10.129	●
250	VP250	267	±1.6	±0.9	12.7	±1.8	240	4,000	15.481	—
300	VP300	318	±1.9	±1.0	15.1	±2.2	286	4,000	21.962	—
350	VM350	370		±1.2	14.3	±2.0	339	4,000	24.378	—
400	VM400	420		±1.3	16.2	±2.2	385	4,000	31.294	—



VP-Straight pipe



HI-VP-Straight pipe

●VU Type

Unit:mm

Nom. Size (mm)	Identification	Outer diameter		Thickness		Approximate Inner diameter	Length	Calculated Weight (kg/m)
		Basic Dimension	Average Tolerance	Min. Dimension	Tolerance			
40	VU 40	48	±0.2	1.8	±0.4	44	4,000	0.413
50	VU 50	60	±0.2	1.8	±0.4	56	4,000	0.521
65	VU 65	76	±0.3	2.2	±0.6	71	4,000	0.825
75	VU 75	89	±0.3	2.7	±0.6	83	4,000	1.159
100	VU100	114	±0.4	3.1	±0.8	107	4,000	1.737
125	VU125	140	±0.5	4.1	±0.8	131	4,000	2.739
150	VU150	165	±0.5	5.1	±0.8	154	4,000	3.941
200	VU200	216	±0.7	6.5	±1.0	202	4,000	6.572
250	VU250	267	±0.9	7.8	±1.2	250	4,000	9.758
300	VU300	318	±1.0	9.2	±1.4	298	4,000	13.701
350	VU350	370	±1.2	10.5	±1.4	348	4,000	18.051
400	VU400	420	±1.3	11.8	±1.6	395	4,000	23.059
450	VU450	470	±1.5	13.2	±1.8	442	4,000	28.875
500	VU500	520	±1.6	14.6	±2.0	489	4,000	35.346

Notes:

- 1.The maximum outer diameter (minimum outer diameter) is the largest(smallest) of outer diameter measurement at a location.
- 2.The average outer diameter is the average for outer diameter measurements made in a direction other than two parallel directions or a circumference measurement divided by 3.142.
- 3.The mass per unit length (m) in the table, which was calculated using a specific gravity of 1.43, is only for information, not part of the standards.
- 4.The length tolerance is ±10mm.
- 5.Pipe VM350 400mm long conforms to the AS24 standard.
- 6.Pipe HI-VP conform to the JIS K6742 standard.



Single-adhesion receptacle straight pipe



Single-rubber ring receptacle straight pipe

AV FLANGES

● TS FLANGES(U-PVC,HI-PVC,C-PVC)

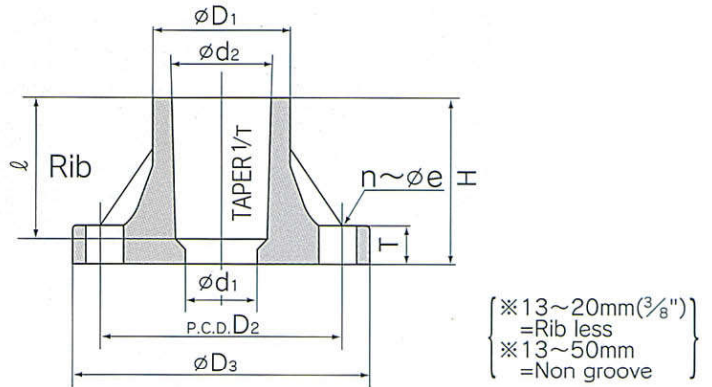

▼ DIMENSIONS TABLE

● JIS

AV TS FLANGES [U-PVC JIS 10K 13mm~350mm($3/8'' \sim 14''$) JIS 5K 13mm~350mm($3/8'' \sim 14''$)
 HI-PVC JIS 10K 13mm~250mm($3/8'' \sim 10''$) JIS 5K 13mm~150mm($3/8'' \sim 6''$)]

Unit:mm

Nominal Size mm(inch)	d ₁	d ₂		Taper 1/T		ℓ		D ₁		D ₂		D ₃		n		e		T		H	
		10K	5K	10K	5K	10K	5K	10K	5K	10K	5K	10K	5K	10K	5K	10K	5K	10K	5K	10K	5K
13 (3/8)	15	18.40		1/30		26	25.5	24	65	55	90	75	4	4	15	12	14	9	30	30	
15 (1/2)	18	22.40		1/34		30	31	29	70	60	95	80	4	4	15	12	14	9	35	35	
20 (3/4)	22	26.45		1/34		35	35	33	75	65	100	85	4	4	15	12	15	10	40	40	
25 (1)	25	32.55		1/34		40	42.5	40	90	75	125	95	4	4	19	12	15	10	46	45	
28 (1)	28	34.55		1/34		40	44.5	42	90	75	125	95	4	4	19	12	16	10	46.5	46	
30(1 1/4)	30	38.60		1/34		44	48.5	46	100	90	135	115	4	4	19	15	16	12	50.5	50	
35(1 1/4)	35	42.60		1/34		44	53.5	51	100	90	135	115	4	4	19	15	16	12	50.5	50	
40(1 1/2)	41	48.70		1/37		55	60.5	59	105	95	140	120	4	4	19	15	16	12	61.5	61	
50 (2)	52	60.80		1/37		63	73	70	120	105	155	130	4	4	19	15	20	14	71	72	
65(2 1/2)	67	76.60	76.80	1/48	1/41	61	69	90	86	140	130	175	155	4	4	19	15	22	14	70	76
80 (3)	78	89.60	89.80	1/49	1/43	64	72	105	101	150	145	185	180	8	4	19	19	22	14	73	80
100 (4)	100	114.70	115.00	1/56	1/44	84	92	131	129	175	165	210	200	8	8	19	19	22	16	93	105
125 (5)	125	140.85	141.20	1/58	1/45	104	112	158	156	210	200	250	235	8	8	23	19	24	16	114	126
150 (6)	146	166.00	166.50	1/63	1/45	132	140	185	185	240	230	280	265	8	8	23	19	26	18	142	150
200 (8)	196	217.00		1/50		145	238	238	290	280	330	320	12	8	23	23	28	28	156	156	
250 (10)	247	268.00		1/55		155	289	289	355	345	400	385	12	12	25	23	30	30	167	167	
300 (12)	298	318.70		1/55		155	341	341	400	390	445	430	16	12	25	23	30	30	167	167	
350 (14)	348	371.00		1/60		230	398	398	445	435	490	480	16	12	25	23	34	34	300	300	

Note : Dimensions shown as D₂,D₃,n,e are accordance with JIS 10K and JIS 5K.
 Dimeter sizes of bolt holes for 5K 300mm(12")are different from JIS 5K.

● JIS

AV TS FLANGES [C-PVC JIS 10K 13mm~150mm($3/8'' \sim 6''$),JIS 5K 13mm~65mm($3/8'' \sim 2 1/2''$)]

Unit:mm

Nominal Size mm(inch)	d ₁	d ₂	Taper 1/T	ℓ	D ₁		D ₂		D ₃		n		e		T		H	
					10K	5K	10K	5K	10K	5K	10K	5K	10K	5K	10K	5K	10K	5K
13 (3/8)	15	18.40	1/30	26	28	24	65	55	90	75	4	4	15	12	14	9	30	30
15 (1/2)	18	22.40	1/34	30	33	31	70	60	95	80	4	4	15	12	14	9	35	35
20 (3/4)	22	26.45	1/34	35	36	33	75	65	100	85	4	4	15	12	14	10	40	40
25 (1)	25	32.55	1/34	40	43	43	90	75	125	95	4	4	19	12	16	10	50	45
30(1 1/4)	30	38.60	1/34	44	51	51	100	90	135	115	4	4	19	15	16	12	50.5	50
40(1 1/2)	41	48.70	1/37	55	65	65	105	95	140	120	4	4	19	15	16	12	65	61
50 (2)	52	60.80	1/37	63	76	76	120	105	155	130	4	4	19	15	20	14	74	72
65(2 1/2)	67	76.80	1/41	69	92	86	140	130	175	155	4	4	19	15	22	14	82	76
80 (3)	78	89.80	1/43	72	108	—	150	—	185	—	8	—	19	—	22	—	86	—
100 (4)	100	115.00	1/44	92	138	—	175	—	210	—	8	—	19	—	22	—	105	—
125 (5)	125	141.20	1/45	112	165	—	210	—	250	—	8	—	23	—	22	—	126	—
150 (6)	146	166.00	1/63	132	185	—	240	—	280	—	8	—	23	—	26	—	142	—

Note : Dimension shown as D₂,D₃,n,e are accordance with JIS 10K and JIS 5K.

AV FLANGES

●ANSI

AV TS FLANGES [U-PVC ANSI 1/2 inch~12inch(15mm~300mm)]

Unit:mm

Nominal Size inch(mm)	d ₁	d ₂	Taper 1/T	ℓ	D ₁	D ₂	D ₃	n	e	T	H
1/2 (15)	18	22.40	1/34	41	31	60.5	89	4	16	12	46
3/4 (20)	22	26.45	1/34	48	35	70	98	4	16	13	53
1 (25)	25	32.55	1/34	40	42.5	79.5	108	4	16	15	50
1 1/4 (30)	30	38.60	1/34	44	48.5	89	117.5	4	16	16	54
1 1/2 (40)	41	48.70	1/37	55	60.5	98.5	127	4	16	18	65
2 (50)	52	60.80	1/37	63	73	120.5	152	4	16	20	74
2 1/2 (65)	67	76.80	1/41	69	90	139.5	178	4	19	23	82
3 (80)	78	89.80	1/43	72	105	152.5	190.5	4	19	24	86
4 (100)	100	115.00	1/44	92	131	190.5	229	8	19	24	107
5 (125)	125	141.20	1/45	112	158	216	254	8	19	24	130
6 (150)	146	166.50	1/45	140	185	241.5	280	8	22	26	150
8 (200)	196	217.00	1/50	145	238	298.5	343	8	22	28	156
10 (250)	247	267.70	1/55	155	289	362	406	12	25	30	167
12 (300)	298	318.70	1/55	155	341	432	483	12	25	30	167

Note : Dimension shown as D₂,D₃,n,e are accordance with ANSI/ASME B 16.5 CLASS 150.
Dimension shown as d₁, ℓ, taper 1/T are accordance with JIS K 6743.

●AV FLANGES(U-PVC,PP)



⓪ FLANGES



Ⓢ FLANGES



Ⓟ FLANGES



Ⓠ FLANGES

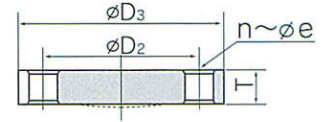
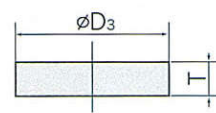
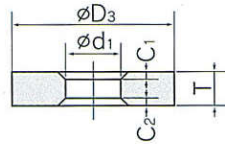
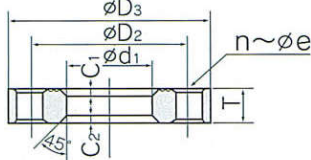

Nominal Size 13mm(3/8")~300mm(12")

※The figure described by broken(dashed) line shows shape of Q-flanges applied for dead end service of piping. 15(1/2")~150mm(6")

▼DIMENSIONS TABLE AV ⓪,Ⓢ,Ⓟ,Ⓠ,FLANGES [U-PVC,PP JIS 10K,5K]

Unit:mm

Nominal Size mm(inch)	d ₁	D ₂		D ₃		n		e		T		C ₁	C ₂
		10K	5K	10K	5K	10K	5K	10K	5K	10K	5K		
13 (3/8)	18	65	55	90	75	4	4	15	12	12	9	3	3
15 (1/2)	22	70	60	95	80	4	4	15	12	12	9	3	3
20 (3/4)	26	75	65	100	85	4	4	15	12	14	10	3	3
25 (1)	32	90	75	125	95	4	4	19	12	14	10	3	3
28 (1)	34	90	75	125	95	4	4	19	12	14	10	3	3
30 (1 1/4)	38	100	90	135	115	4	4	19	15	16	12	3	3
35 (1 1/4)	42	100	90	135	115	4	4	19	15	16	12	3	3
40 (1 1/2)	48	105	95	140	120	4	4	19	15	16	12	3	3
50 (2)	60	120	105	155	130	4	4	19	15	16	14	3	4
65 (2 1/2)	76	140	130	175	155	4	4	19	15	18	14	3	4
80 (3)	89	150	145	185	180	8	4	19	19	18	14	3	4
100 (4)	114	175	165	210	200	8	8	19	19	18	16	3	4
125 (5)	140	210	200	250	235	8	8	23	19	20	16	4	4
150 (6)	165	240	230	280	265	8	8	23	19	22	18	4	4
200 (8)	216	290	280	330	320	12	8	23	23	22	20	4	4
250 (10)	267	355	345	400	385	12	12	25	23	24	22	4	4
300 (12)	318	400	390	445	430	16	12	25	23	24	22	4	4

- ⓪ and Ⓢ are welded flanges.
- Ⓟ and Ⓠ are blind flanges.

Note : Dimension shown as D₂,D₃,n,e are accordance with JIS 10K and JIS 5K.

AV GASKETS



Full face Type Rubber Gasket



Ring Type Gasket (JIS only)



PTFE coated

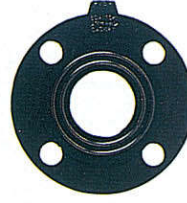

PVDF coated

● MATERIAL : EPDM, PTFE, PVDF, CSM, FPM, IIR, others

FEATURES

- AV GASKETS offer Similar sealing performance with 1/3 bolt tightening torque, compared to flat or envelope style gaskets.
- Uniform dimension, fine surface, suitable hardness.
- Long service life.
- Unique Convex Design.

WORKING TEMPERATURE AND SIZE AVAILABILITY

MATERIAL	WORKING TEMPERATURE °C(° F)	SIZE AVAILABILITY BY STANDARD		
		JIS	ANSI	DIN
EPDM	-40°C~ 90°C (-40°F~195°F)	15mm-350mm	1/2" -16"	15mm-350mm
PTFE	-40°C~120°C (-40°F~250°F)	15mm-300mm	1/2" -12"	15mm-300mm
PVDF	-40°C~120°C (-40°F~250°F)	15mm-300mm	1/2" -10" *	15mm-300mm

Working temperature is different depending on type of fluid.

* Except for 1 1/4" and 2 1/2"

DRAWING-DIMENSIONS

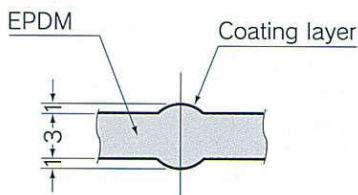
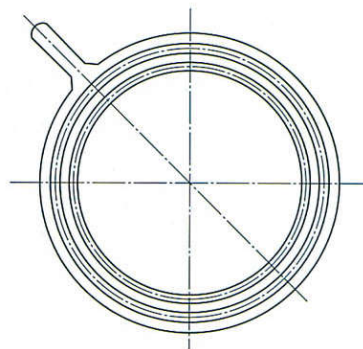
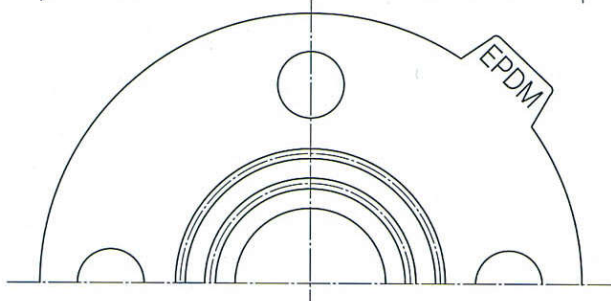
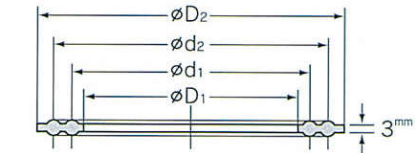
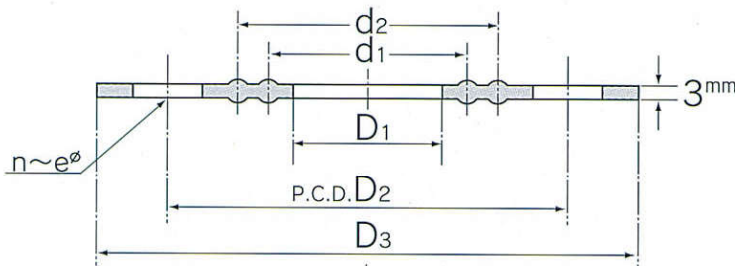

TYPE	Nom, Size	Thickness
PTFE	15mm(1/2") to 300mm(12")	0.4mm(0.016")
PVDF	15mm(1/2") to 65mm(2 1/2")	0.4mm(0.016")
	80mm(3") to 300mm(12")	0.5mm(0.02")

TS & DV FITTINGS

● TS FITTINGS (JIS K6743) (U-PVC: 13 to 150mm, HI-PVC: 13 to 150mm)

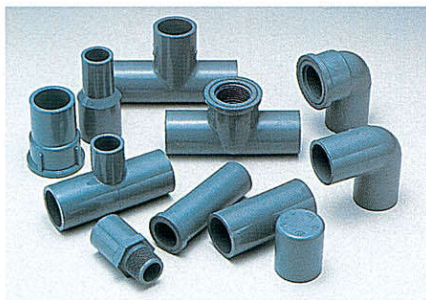

Elbows	(L)	13~150mm
Tees	(T)	13~150×125mm
Water feeding elbows	(FL)	13~25mm
Metal-containing water feeding elbows		13~25mm
Water feeding sockets	(FS)	13~25mm
Metal-containing water feeding sockets		13~25mm
Water feeding tees	(FT)	13~25×20mm
Metal-containing water feeding tees		13~25×20mm
Valve sockets	(VS)	13~150mm
Union sockets	(US)	13~50mm
Sockets	(S)	13~150×125mm
Caps	(C)	13~150mm

● DV FITTINGS (JIS K6739) (Nominal Size: 40 to 150mm)



90° elbows	(DL)	30~150mm
90° large-curvature elbows	(LL)	40~150mm
45° elbows	(45L)	30~150mm
90° Y	(DT)	30~150×100mm
90° large-curvature Y		40~150×125mm
90° large-curvature both-sided Y	(WLT)	65~125×100mm
45° Y	(Y)	40~150×100mm
Sockets	(DS)	40~150mm
Increases	(IN)	40~30~150×125mm

※We also produce VU FITTINGS

SEMENT



AV No.32
(Blue can)
100g·500g·1kg



AV No.52
(Red can)
500g



AV No.62
(Yellow can)
1kg



AV HI No.90
(Dark blue can)
500g



AV super No.88
(Brown can)
250g·500g

※These adhesives are classified under Dangerous Substance Class 4, the First Oil-Based Material specified in Article 2 of the Japanese Fire Prevention Act. Use utmost care when storing the adhesives.

FEATURES

- AV adhesives No.32 and No.52 are suitable for small AV TS flanges and FITTINGS.
- AV adhesive No.62 is suitable for large AV FITTINGS and AV DV FITTINGS.

▼ SPECIFICATIONS

Items	Feature	Color of Vessel	Viscosity (cp)	Reduction by drying(%)	Cementing strength(kgf/cm ²)	
					after 15min.	after 2 hours
AV No.32	Low viscosity, quick drying	Blue	100~ 500	30~50	over 12.5	over 25
AV No.52	High viscosity, quick drying	Red	500~3.000	30~50	over 12.5	over 25
AV No.62	High viscosity, slow drying	Yellow	500~3.000	10~30	—	over 25
AV No.90	High viscosity, quick drying	Dark blue	500~3.000	30~50	over 12.5	over 25

Standard Quantity of "AV ADHESIVES" required for connecting "AV U-PVC PIPE" with "AV FITTINGS."

Unit:g

Nominal Size(mm)	13	16	20	25	30	40	50	65	75	100	125	150	200	250	300	350	400	450	500	
Applying Quantity at one paint	0.9	1.2	1.7	2.0	3.1	5.0	7.1	9.9	12.0	20	30	44	81	126	180	244	318	400	490	
Application	Summer Season	●AV adhesive 32 or AV adhesive 52											●AV adhesive 62							
	Winter Season	●AV adhesive 32											●AV adhesive 52 or AV adhesive 62							

PRECAUTIONS FOR USE

- For installation and maintenance procedure refer to the appropriate manual for the product being used.
- Do not drop or toss piping material.
- Do not step on a valve.
- Do not put anything heavy on a valve.
- Do not put anything burning or hot near a valve.
- Do not scratch or thrust a valve with anything sharp (such as a knife and a hanger).
- Avoid contacting with any coal tar creosote (antiseptic for wood), termite insecticide, vermicides, or paint.
- Secure sufficient space for maintenance and inspection.
- Select piping material suitable for your specific needs, using "Chemical Resistance On Asahi AV Valve," as a guide. If you have any questions, please feel free to contact your nearest Asahi dealer.
- Be sure to use water pressure when testing a pipeline including AV piping material.

It is extremely dangerous to use air pressure for testing the pipeline.

- The pressure limit includes water hammer pressure. Do not exceed the limit.
- In discarding a valve, be sure to ask a waste service company.
- Valve should not be used with compressed air or gas.
- If you have any questions, please feel free to contact your nearest Asahi dealer.



仲賢行有限公司
CYH Limited

Rm 911, 9/F, Harbour Crystal Centre, 100 Granville Road, Tsim Sha Tsui East, Kln., H.K.
香港九龍尖沙咀東部加連威老道100號港晶中心9樓911室

(852) 2967 3999 (852) 2818 6890



ASAHI ORGANIC CHEMICALS INDUSTRY CO.,LTD.

- Head Office : 2-5955,Nakanose-cho,Nobeoka-City,Miyazaki-Pref.,Japan
- Tokyo Office : (Furukawachiyoda Bldg.) 15-9,Uchikanda 2-chome,Chiyoda-ku,Tokyo,Japan
- Singapore Representative Office : 16 Raffles Quay, #40-03 Hong Leong Building,Singapore 048581
- Europe Representative Office : Am Wehrhahn 33,40211,Duesseldorf,Germany
- Asahi/America, Inc. : 35 Green Street P.O. Box 653, Malden Massachusetts, 02148 U.S.A